

Eclipse ThermJet

Burners

Model TJ0015

Version 2.7

Parameter	Burner Velocity	Model TJ0015	
Maximum Input, Btu/h (kW)	Medium & High Velocity	150,000 (44)	
Minimum Input On-Ratio, Btu/h (kW)	Medium & High Velocity	15,000 (4.4)	
Minimum Input Fixed Air, Btu/h (kW)	Medium & High Velocity	3,750 (1.1)	
Gas Inlet Pressure Required, "w.c. (mbar) Tap B (see page 3)	High Velocity	Natural Gas	13.0 (32.4)
		Propane	15.0 (37.4)
		Butane	15.0 (37.4)
	Medium Velocity	Natural Gas	7.5 (18.7)
		Propane	7.5 (18.7)
		Butane	7.5 (18.7)
Air Inlet Pressure Required, "w.c. (mbar) 15% Excess Air at Maximum Input Tap A (see page 3)	High Velocity	Natural Gas	17.0 (42.3)
		Propane	18.0 (44.8)
		Butane	18.0 (44.8)
	Medium Velocity	Natural Gas	11.0 (27.4)
		Propane	11.0 (27.4)
		Butane	11.0 (27.4)
High Fire Flame Length, inches (mm) <i>Measured from the outlet end of the combustor</i>	High Velocity	Natural Gas	9.0 (229)
		Propane	9.0 (229)
		Butane	9.0 (229)
	Medium Velocity	Natural Gas	11.0 (279)
		Propane	10.0 (254)
		Butane	11.0 (279)
Approximate Flame Velocity, ft/s (m/s) 15% Excess Air at Maximum Input	High Velocity	440 (134)	
	Medium Velocity	270 (82)	
Maximum Combustion Air Temperature	300°F (149°C). For higher temperatures use TJPCA (Datasheet 206).		
Flame Detection	Flame rods can be used with all combustors, natural gas, and operating temperatures up to 2,200°F (1,204°C). UV scanners can be used with all combustors, any fuel listed below, and up to the maximum operating temperature.		
Fuel <i>For any other mixed gas, contact Eclipse, Inc.</i>	Natural gas, propane or butane ¹		
Approvals			

1. See Design Guide 205 for more information about typical fuel composition and properties

- All information is based on laboratory testing in neutral (0 "w.c., 0 mbar) pressure chamber. Different chamber conditions may affect the data.
- All information is based on standard combustor design. Changes in combustor will alter performance and pressures.
- All inputs based upon gross calorific values and standard conditions; 1 atmosphere, 70°F (21°C).
- Eclipse reserves the right to change the construction and/or configuration of our products at any time without being obliged to adjust earlier supplies accordingly.
- Plumbing of air and gas will affect accuracy of orifice readings. All information is based on generally acceptable air and gas piping practices.

Performance Graphs

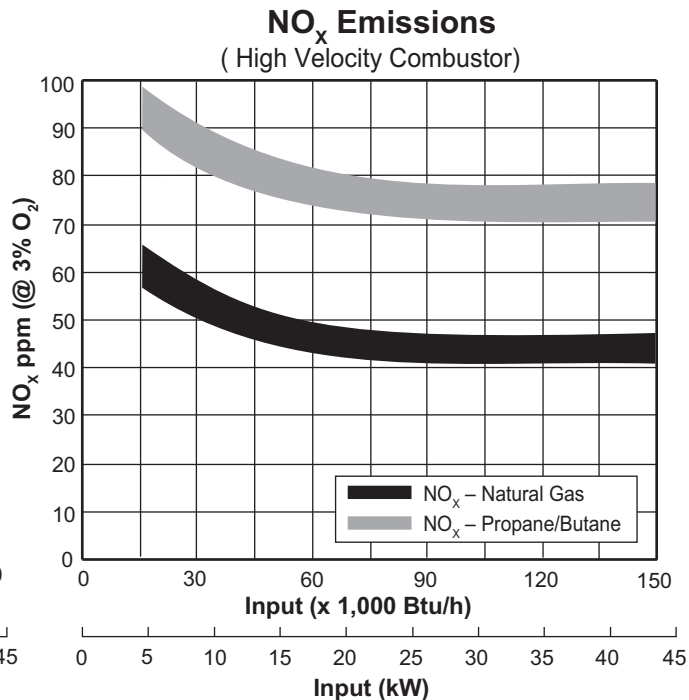
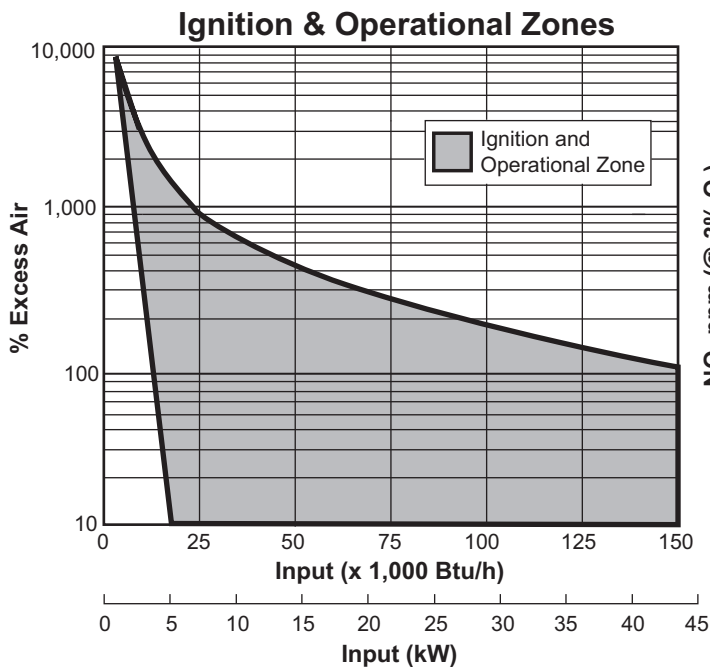

Emissions correction factor for medium velocity combustor is 1.20. Emissions data based on, on-ratio control firing at 15% excess air corrected to 3% O₂.

Emissions from the burner are influenced by:

- Fuel type
- Combustion air temperature
- Firing rate
- Chamber conditions
- Percent of excess air

For estimates of other emissions, contact Eclipse.

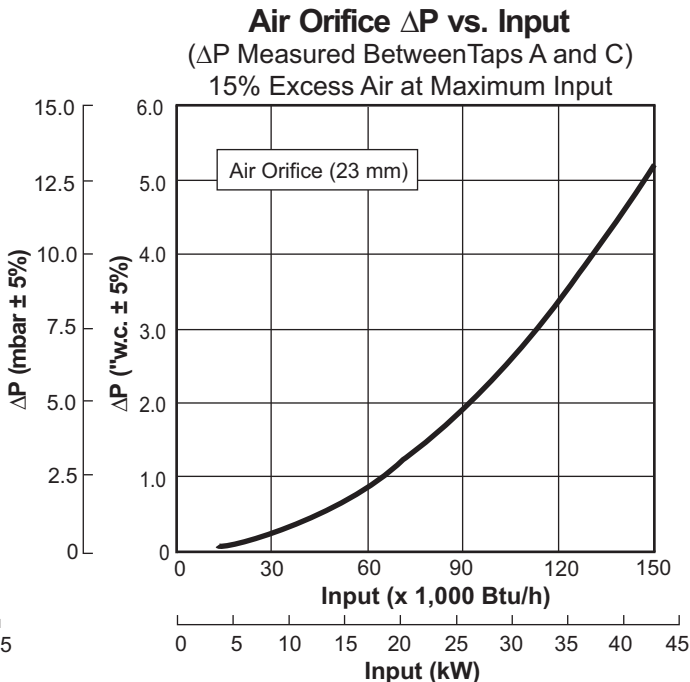
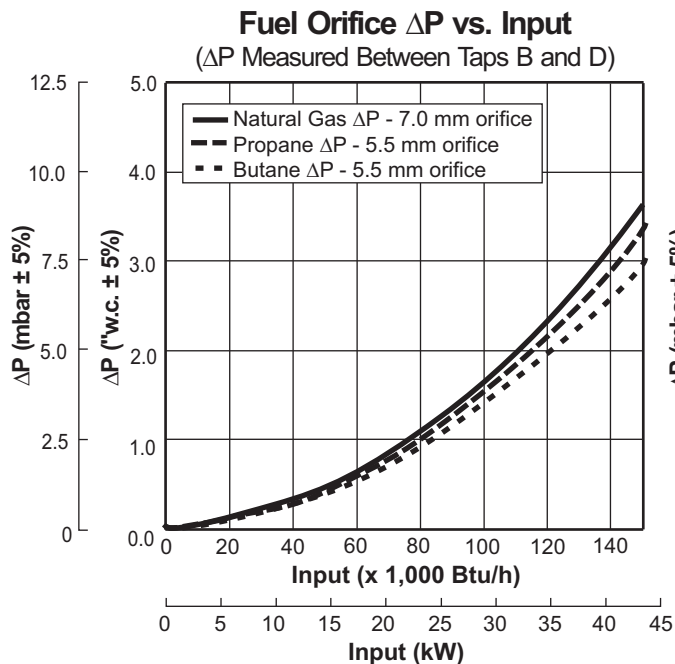

Dimensions and Specifications

Dimensions in mm (inches)

Burner Housing

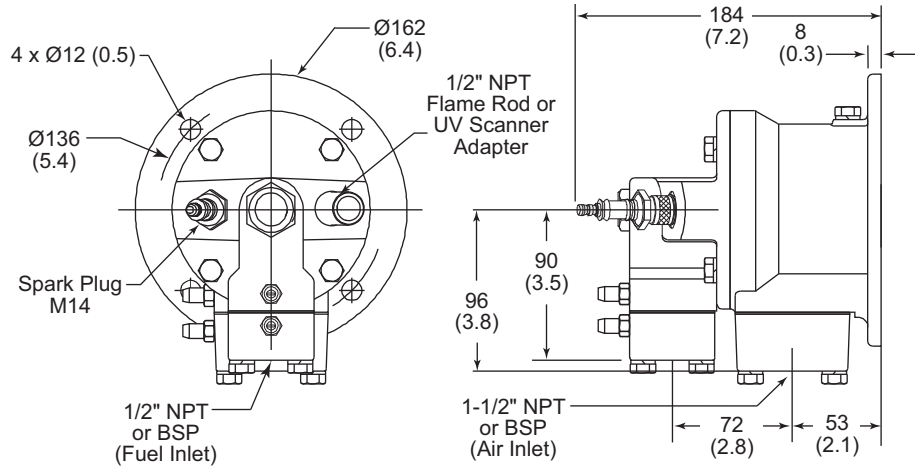

Burner weight less combustor: 17.9 lbs (8.1 kg)

Tap Locations

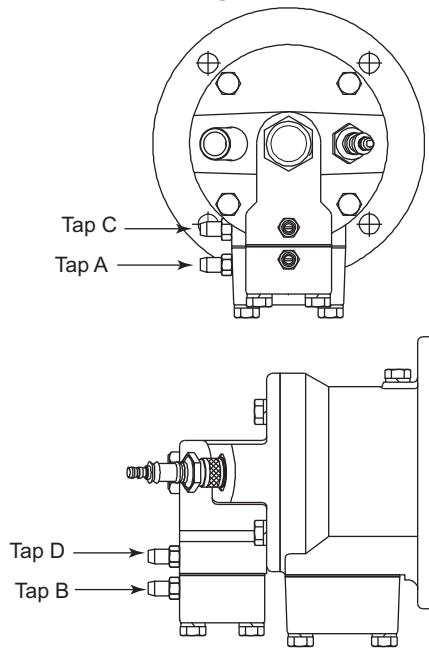

Dimensions and Specifications

Dimensions in mm (inches)

Combustors

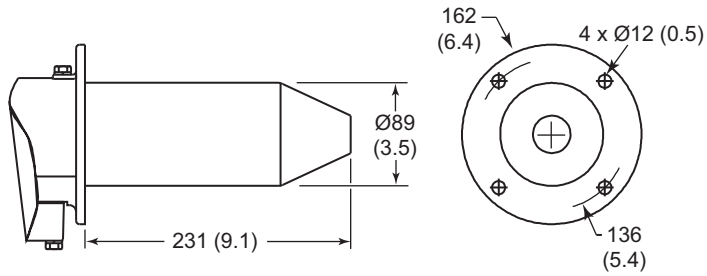

Alloy Combustor (AISI 310)

Weight: 2.1 lbs (0.95 kg)

Maximum Chamber Temp: 1,750°F (950°C)

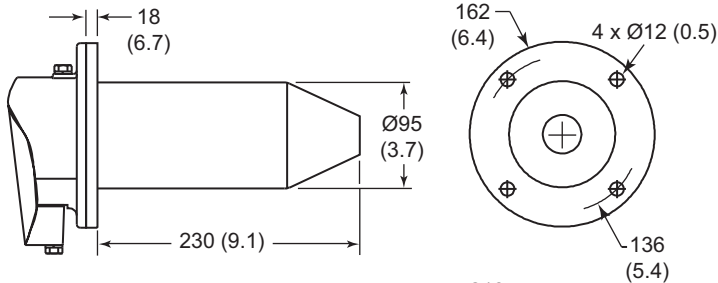

Silicon Carbide Combustor

Weight: 3.6 lbs (1.6 kg)

Maximum Chamber Temp: 2,500°F (1,371°C)

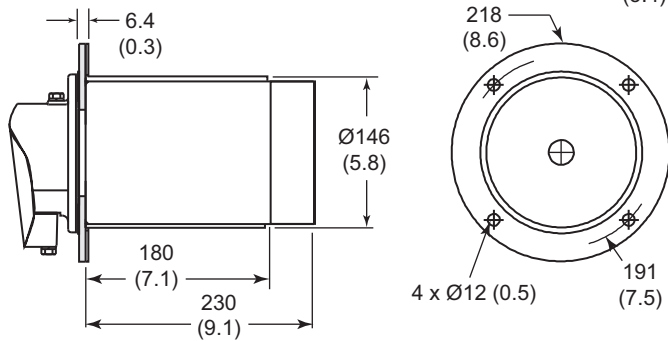

Refractory Combustor with AISI 330 wrapper

Weight: 14 lbs (6.4 kg)

Maximum Chamber Temp: 2,800°F (1,538°C)

Exhaust Outlet Diameter:

High Velocity (H): Ø25 (1.0)

Medium Velocity (M): Ø32 (1.3)